

GENERAL INFORMATION

Project Name: _____
 Item: _____
 Quantity: _____
 Model: DECO-200-N
 Length: _____

STANDARD NSF LISTED FINISH OPTIONS

- | | |
|---|--|
| <input type="checkbox"/> Stainless Steel #4 | <input type="checkbox"/> Chrome |
| <input type="checkbox"/> Gloss Black | <input type="checkbox"/> Wrinkle Black |
| <input type="checkbox"/> Smoked Copper | <input type="checkbox"/> Polished Brass Finish |
| <input type="checkbox"/> Other _____ | |

TUBE OPTIONS

- | | |
|--|--|
| <input type="checkbox"/> 1-1/2" Round (standard) | <input type="checkbox"/> 1" Round Diameter |
| <input type="checkbox"/> 1" Square | <input type="checkbox"/> 1-1/2" Square |

GLASS THICKNESS

- | |
|---|
| <input type="checkbox"/> 1/4" Tempered Glass (not for shelves)
Centerline Max 54" |
| <input type="checkbox"/> 3/8" Tempered Glass (standard) (for shelf or span more than 54")
Centerline Max 66" |
| <input type="checkbox"/> 1/2" Tempered Glass (for shelf or span more than 66")
Centerline Max 72" |

GLASS PANEL OPTIONS

- Full Perimeter Channel

TOP SHELF OPTIONS

- | | |
|---|---|
| <input type="checkbox"/> 1/2" Tempered Glass | <input type="checkbox"/> 3/8" Tempered Glass |
| <input type="checkbox"/> #8 Mirror Polished Brass | |
| <input type="checkbox"/> Stainless: | <input type="checkbox"/> #4 Brushed <input type="checkbox"/> #8 Mirror Polished |
| <input type="checkbox"/> Powder Coated | Color _____ |
| <input type="checkbox"/> Solid Surface | Material _____ |

INSTALLATION OPTIONS

- | | | |
|--|--|---------------------------------------|
| <input type="checkbox"/> Above-Counter: Round Tube | <input type="checkbox"/> Narrow Flange | <input type="checkbox"/> Round Flange |
| <input type="checkbox"/> Above-Counter: Square Tube | | |
| <input type="checkbox"/> Under-Counter: Round Tube | | |
| <input type="checkbox"/> Under-Counter: Square Tube | | |

See Installation Page for More Information.

* Approval Drawings Required

Specifications subject to change without notice.

DECO-200-N

Self-Serve Food Shield



Shown without end panels.

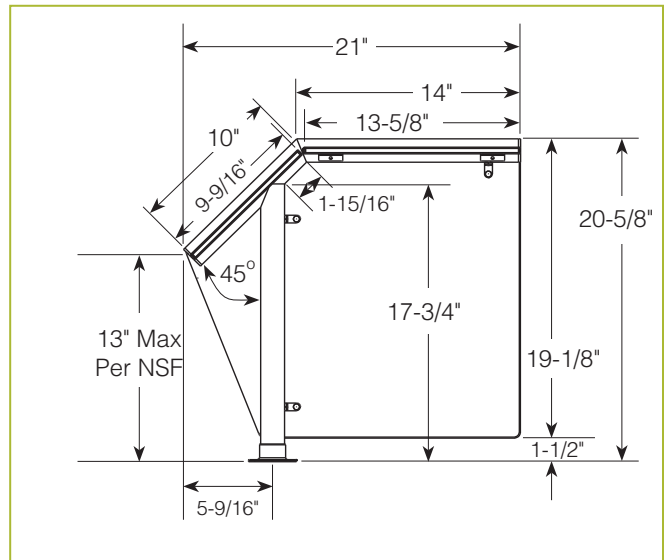

To meet NSF guidelines, end panels are included on all BSI quotations unless specifically excluded.

Shipped Fully Assembled

LIGHT AND WARMER OPTIONS

- LED Light Unit
- Linear T-5 Fluorescent Unit
- BSI Stealth™ Linear Heat Only Unit
- BSI Stealth™ Linear Heat and Light Combo Unit (Fluorescent)
- BSI Stealth™ Linear Heat and Light Combo Unit (LED)
- BSI Stealth™ Linear Double Heat and Light Combo Unit (Fluorescent)
- BSI Stealth™ Linear Double Heat and Light Combo Unit (LED)
- Hatco® Brand Heat Only Unit
- Hatco® Brand Heat and Light Combo Unit

Structural enhancements or mounting might be required to support heat light options.