

## GENERAL INFORMATION

**Project Name:** \_\_\_\_\_  
**Item:** \_\_\_\_\_  
**Quantity:** \_\_\_\_\_  
**Model:** HSD-ST  
**Length:** \_\_\_\_\_

## DESCRIPTION

Meet the latest health department requirements with minimal impact on space requirements. The BSI HSD-ST allows hand sinks to be spaced closely throughout prep areas and servery counters without consuming valuable counter-top space. The HSD-ST module is designed to be easily integrated into new fabrication or retro-fitted into existing equipment.

## GENERAL SPECIFICATION

### Materials

- 16-Gauge Brushed Finish Type 304 Stainless Hand Sink
- 18-Gauge Brushed Finish Type 304 Stainless Enclosures
- 14-Gauge Stainless Heavy-Duty Roller Bearing Drawer Slides
- Flexible Hoses Plumbed to Hard Points for Final Plumbing Connection
- Soap Dispenser

### Construction

- NSF Standard 2 Construction
- Fully Welded Sink and Seamless Top
- Tilt-Out Towel Compartment
- 3/4" Mounting Flange with Stud Holes every 4"

## SINK FAUCET OPTIONS

- Infrared Faucet
- Single Deck Dual Control Faucet with 6" Swing Spout
- Customer Supplied Faucet  
 Make \_\_\_\_\_ Model \_\_\_\_\_

*This unit can be plumbed in the field to a floor drain if available or to a 1-1/2" drain pipe. 1/2" MPT for cold water connection only with less than 45 psi.*

## HSD-ST

### Hand Sink Drawer with Soap and Towel Dispenser

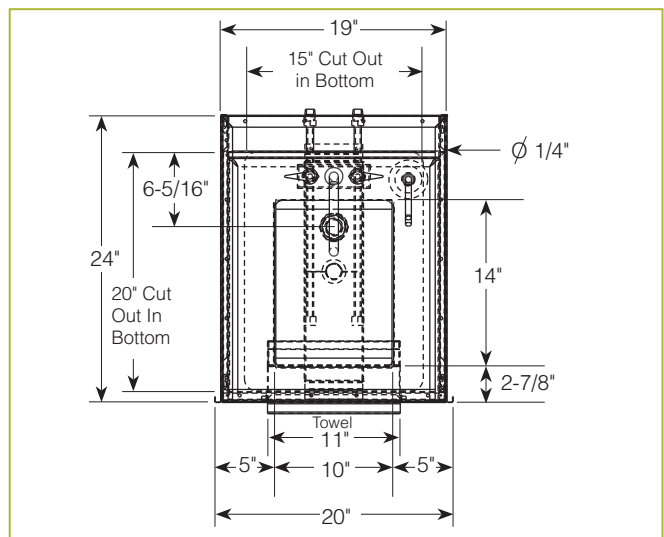
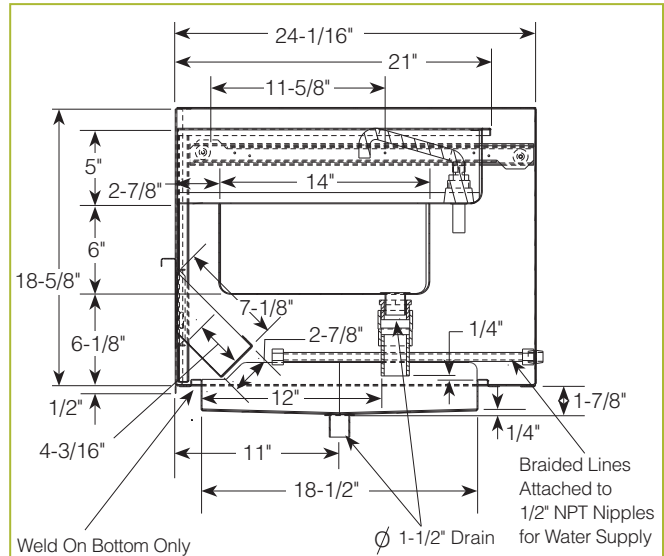

## \* Approval Drawings Required

Specifications subject to change without notice.