

GENERAL INFORMATION

Project Name: _____
Item: _____
Quantity: _____
Model: CUSTOM CONDIMENT CART
Length: _____

STANDARD FEATURES

- 16 gauge #304 stainless steel countertop
- 18 gauge #304 stainless steel trim
- 6" casters, two (2) rigid and two (2) swivel with brakes
- Black rubber caster skirt on three (3) sides
- Powder coated exterior panels
- Locking stainless steel storage compartment
- Stainless steel - glass food guard
- Stainless steel ice bin (drop-in)
- U.L. Listed
- NSF Listed to Standard 59

OPTIONS

- Drop shelf
- Vinyl bumper
- Custom graphics
- Cart cover

EQUIPMENT SUPPLIED

- Automatic condiment dispensers
- Napkin dispensers
- Undercounter refrigerator
- Bag-n-box slide out rack system for condiments

EQUIPMENT SUPPLIED OTHERS

- CO2 tank - 10 pound

CUSTOM CONDIMENT CART

6' Cart (with CO2 Dispensing System)

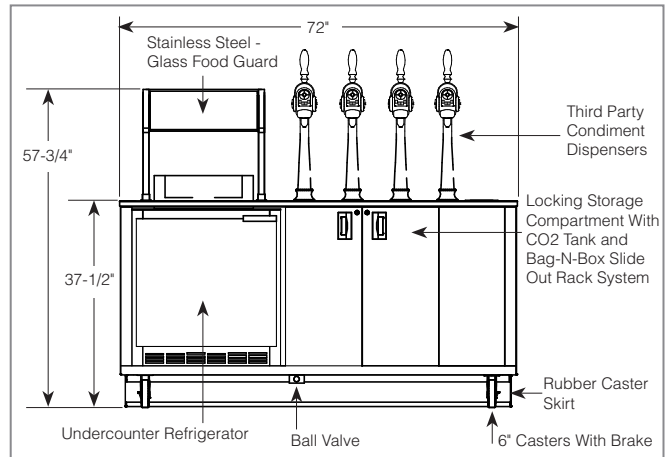
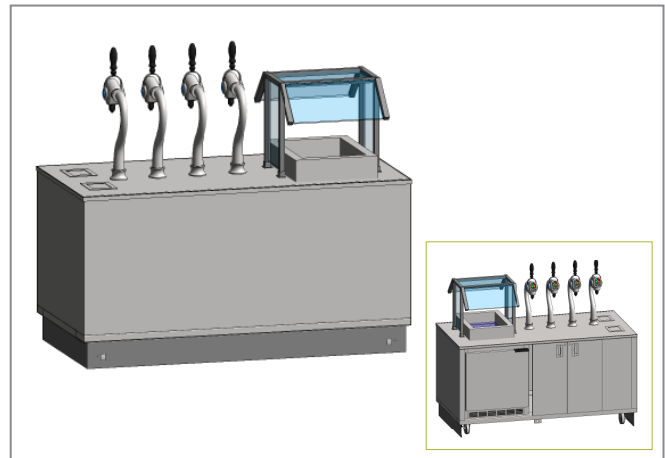

All fixtures and equipment to be connected to a single load center. Cart to have one (1) 8' power cable with a NEMA 5-20P plug.

PLUMBING NOTES

Ice bins to drain to a ball valve located below the cart.