

THE BSI DIFFERENCE

Across the foodservice landscape, fabricators of varying size and capability offer counters for a variety of applications. So what sets BSI apart from the competition? Flexibility, customization and end-to-end service.

Flexibility

In many cases, achieving the desired look and functionality at a price that delivers value requires a combination of counter construction methods.

Customization

BSI encourages designers to unlock their creativity by offering unmatched construction and finish options to help achieve each customer's desired design.

End-to-End Service

From pre-sale drawings to installation supervision, BSI works with you every step of the way to ensure your project is on time and built to specification.



THE POWER OF CONTOURA

Contoura counters uniquely combine the ease of modular counters with the beauty and freedom of custom fabrication. Constructed with heavy-duty stainless steel structural panels, sections are bolted together using horizontal channels that serve as both chaseways and support, ensuring your project is on time and built to specification.

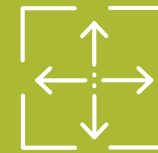

Available in virtually any length, height and width



Specifiable for consultants and dealers



Offered in a wide variety of front finish materials and substrates

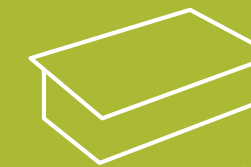

Ideal for serving lines with extensive drop-in equipment

CONTOURA CONSTRUCTION



By bolting sections together, welding and polishing are minimized, reducing production time and simplifying installation. Decorative fronts are separate from the structure, making them easy to update or replace design elements.

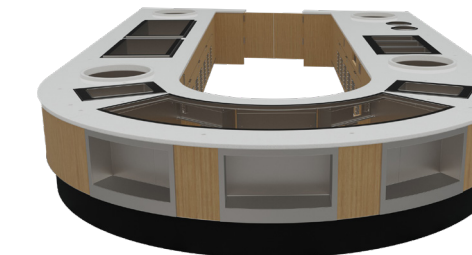

Whether you are creating curved counters, islands, or straight runs, a pre-engineered counter system simplifies design, fabrication, and installation without sacrificing functionality.



QUALITY MATERIALS

Thicker-gauge stainless steel selected for durability in high-volume kitchen environments.



EXPERIENCED CRAFTSMANSHIP

Highly tenured welding and assembly professionals who bring precision to every detail.

ALTERNATIVE CONSTRUCTION METHODS

Unibody (a)

The most recognized construction technique for serving lines, Unibody features stainless steel sides and shelves for durable, sanitary, and easy-to-clean counters. Ideal for long-term installations with minimal anticipated aesthetic variation.

Angle Frame (b)

A cost-effective, all-metal option utilizing stainless or galvanized angles. Counters are open underneath and best suited for areas enclosed by walls. Additional structural support may be required for stone or solid-surface tops.

Millwork (c)

Counters constructed from stained or laminated wood, offering broad finish options and design flexibility. Considerations include moisture exposure, food zone restrictions, and clearance requirements.

Open Base (d)

An affordable, time-saving choice for long, straight counter runs where speed and efficiency are priorities.

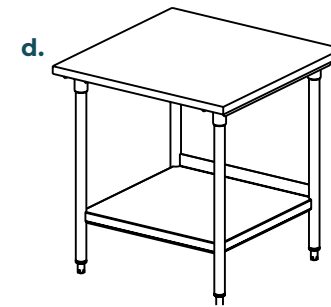
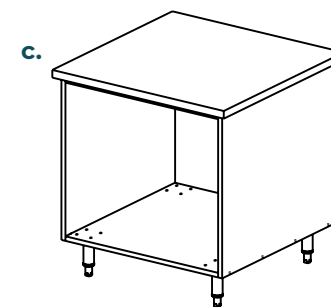
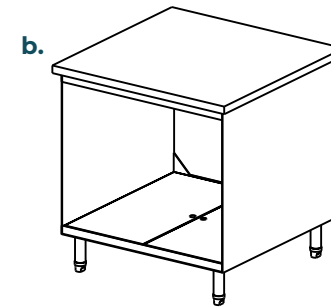
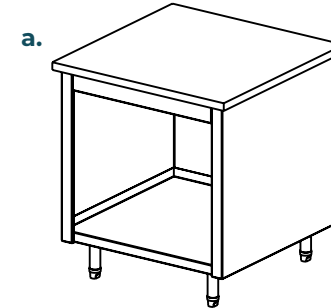

FINISH OPTIONS, COUNTERTOPS & BUILT-INS

Front Finish Options

- Decorative wood panels, planks, or custom millwork
- Laminate finishes
- Tilework applied on site
- Painted or stained millwork (not NSF approved)
- Stainless steel and specialty finishes



Built-Ins & Buyouts

BSI is the industry leader in adjustable and fixed food shields, and a premier provider of lights, warmers and stainless steel accessories. As the only end-to-end counter solutions provider, BSI installs specified buyouts, regardless of manufacturer, prior to shipment, saving time and money during field installation.



Watch how our pre-shipment services set you up for success at the jobsite.

COUNTERTOPS

BSI is the only foodservice counter manufacturer with a wholly owned stone shop in the same manufacturing facility — Colorado Custom Stone. Countertops are installed prior to shipment to ensure optimal fit and finish while reducing field installation time and cost.

Available materials include quartz, solid surface, granite*, marble*, stainless steel and laminate.

*Not NSF approved.

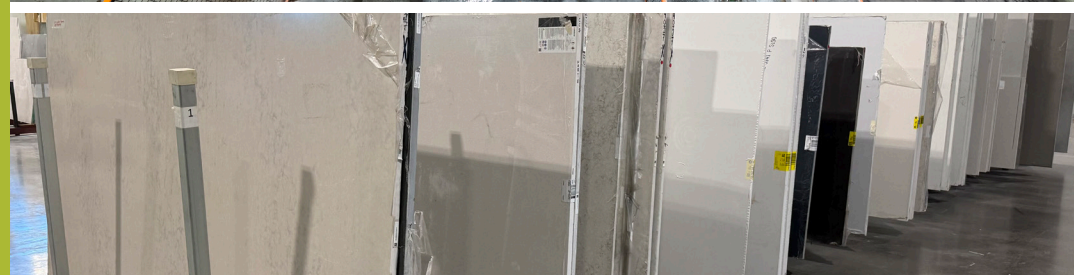

800.662.9595 • www.bsidesigns.com

BSI

COUNTER
CONSTRUCTION